

GRADALL®

XL 4200^{II}

HYDRAULIC EXCAVATOR



XL 4200^{II}

SPECIFICATIONS

Upperstructure Engine

Deere 6068TF275 diesel, turbocharged, liquid cooled, 4 cycle, 6 cylinder, 414 cid (6.8 L) 4.19" bore x 5.00" stroke (106 mm x 127 mm) 170:1 compression ratio.

166 hp (124 kW) gross at 2,200 rpm, 146 hp (109 kW) net at 2,200 rpm. 429 ft-lb (582 Nm) gross torque at 1400 rpm.

Altitude capability: 10,000' (3,048 m). Derate 4% per 1,000' (305 m) above 10,000' (3,048 m).

Maximum slope: 45°

12 volt starter, 105 amp alternator, two SAE #C31-S 810 CCA batteries, two-stage dry type air cleaner with centrifugal precleaner and safety element. Evacuator valve and service indicator, spin-on oil filter, spin-on fuel filter/water separator.

Fuel tank capacity: 92 gallons (348 L).

Hydraulic System

PUMPS

One load-sensing, axial piston pump; oil flow 84 GPM (0-317 L/min).

SYSTEM MONITOR

Electronic monitor in cab indicates low hydraulic fluid level, high hydraulic fluid temperature, and condition of hydraulic suction and return filters.

SYSTEM SPECIFICATIONS

Four double acting cylinders

- 1 tool: 5.0" ID, 3.0" rod (127 mm x 76 mm), 22.5" (572 mm) stroke.
- 2 hoist: 4.25" ID, 3.15" rod (108 mm x 80 mm), 31.0" (787 mm) stroke.
- 1 telescope: 3.5" ID, 2.559" rod (89 mm x 65 mm), 12'6" (3.81 m) stroke.

Four hydraulic motors

Swing, 51Hp (38 kW); tilt, 18 Hp (13 kW); two crawler drives, 120 Hp (89 kW) each.

Operating pressures:

Hoist.....	4,900 psi	(33,784 kPa)
Tilt.....	2,200 psi	(15,168 kPa)
Swing.....	4,200 psi	(28,958 kPa)
Tool.....	4,900 psi	(33,784 kPa)
Telescope.....	4,900 psi	(33,784 kPa)
Crawler.....	4,900 psi	(33,784 kPa)
Pilot System.....	500 psi	(3,448 kPa)

Oil Capacity

Reservoir 48 gallons (182 L), system 68 gallons (257 L). Pressurized reservoir with visual oil level gauges.

Filtration System

10 micron return filter with magnet and 100 mesh suction strainer in reservoir.

Fin and tube-type oil cooler with thermal by-pass and relief valves.

Pressure-compensated, load-sensing valves with circuit reliefs in all circuits.

Tractor type crawler with triple grouser heavy-duty pads.

Sealed track links, lubricated and sealed idlers and rollers, hydraulic track tension adjustment, track guides, motor and hose guards, front and rear tow eyes.

Track length:

13' 8" (4.2 m)

Track pads:

23.6" (600 mm) or 31.5" (800 mm)

Crawler width:

10' 6" (3.2 m) w/31.5" (800 mm) pads

9' 10" (3 m) w/23.6" (600 mm) pads

Ground clearance:

18" (457 mm)

Upperstructure Cab

All-weather cab with tinted safety glass windows, wiper/washer, skylight, acoustical lining, four-way adjustable suspension operator's seat, filtered fresh air heater and defroster. Front window slides to overhead storage. Rear view mirrors on right and left sides of the machine.

Controls

Two hydraulic joysticks (hoist & bucket, telescope & swing), one rocker switch (tilt) control upperstructure. Hydraulic joysticks are mounted on arm pods that are adjustable for individual operator comfort and convenience.

Two hydraulically damped foot pedals (with handles) control crawler steering, travel and brakes. Toggle switch on arm pod for selection of crawler speed range.

Joysticks are self-centering; when the controls are released, power for movement disengages and swing, tilt and crawler brakes set automatically.

Engine Controls and Instrumentation

Key operated ignition/starter switch, throttle, hour meter and air cleaner condition indicator. Electronic monitor indicates fuel level, low battery charge, coolant level, hydraulic oil level, lube oil pressure, high coolant temperature, and engine rpm. Fuel saving auto idle feature sends engine rpm to idle when control circuits are in neutral for seven seconds.

Swing

Priority swing circuit with axial piston motor. Planetary transmission.

Swing Speed: 8.0 rpm.

Swing Brake

Automatic spring-set/hydraulic release wet disc parking brake. Dynamic braking is provided by the hydraulic system.

Crawler Drive

Dual range, high torque piston motor powers each track. Three-stage planetary drive with integral speed limiting valve and automatic spring-set/hydraulic release wet disc parking brake.

Travel Speed on flat, level surface:

High Speed: 3.4 mph (5.5 km/h)

Low Speed: 1.9 mph (3.1 km/h)

Automatic two-speed control shifts crawler drive into low speed under difficult travel conditions. Manual override switch for loading the machine for transport.

Gradeability

100%, limited by engine lubrication requirements.

Drawbar Pull

38,324 lb (170 kN)

Individual Track Control

Tracks counter-rotate to pivot machine about the swing centerline. Electronically operated travel alarm signals crawler movement in either direction.

Function Forces

Rated Boom Force:

22,075 lb (98.2 kN)

Rated Bucket Breakout Force:

25,449 lb (113.2 kN)

Weight

Approximate working weight with 36" (914mm) excavating bucket, fuel tank half full, and no operator.

Pad Size	Weight	Bearing Pressure
31.5" 800mm	43,450 lb (19,708 kg)	5.27 psi (36.3 kPa)
23.6" 600mm	42,334 lb (19,202 kg)	6.83 psi (47.1 kPa)

GRADALL XL 4200 Rated Lift Capacity Over End or Side: lb (kg)

LOAD POINT HEIGHT		LOAD RADIUS					
		10' (3.0 m)	15' (4.6 m)	20' (6.1 m)	25' (7.6 m)	MAXIMUM RADIUS	
Above Ground Level	15' (4.6 m)		9865 (4475)	6980 (3165)	5135 (2330)	25' 2" (7.7 m)	5075 (2300)
	10' (3.0 m)		11825 (5365)	7940 (3600)	5690 (2580)	26' 8" (8.1 m)	5145 (2335)
	Boom Level 8'6" (2.4 m)		12415 (5630)	8230 (3735)	5855 (2655)	26' 11" (8.2 m)	5195 (2355)
	5' (1.5 m)		12635 (5730)	8390 (3805)	5970 (2710)	27' 0" (8.2 m)	5270 (2390)
At Ground Level			11545 (5235)	8095 (3670)	5895 (2675)	26' 5" (8.0 m)	5430 (2465)
Below Ground Level	5' (1.5 m)	10955 (4970)	9395 (4260)	7220 (3275)		24' 8" (7.5 m)	5600 (2540)
	10' (3.0 m)	7235 (3280)	7265 (3295)	6100 (2765)		21' 7" (6.6 m)	5710 (2590)
	15' (4.6 m)	4850 (2200)	5520 (2505)			16' 2" (4.9 m)	5450 (2470)

The above loads are in compliance with SAE Standard J1097 NOV88. They do not exceed 87% of hydraulic lifting capacity or 75% of tipping capacity.

All loads shown are limited by hydraulic lift capacity rather than stability.

The rated lift capacity is based on the machine being equipped with 7500 lb (3400 kg) counterweight, standard boom, standard tires, no auxiliary hydraulics, and no bucket.

Adjust the listed rated capacities by subtracting the value listed for bucket/attachment used:

8065-6007	60" (1.5 m)	Ditching	820 lbs. (370 kg)
8065-6006	66" (1.7 m)	Ditching	905 lbs. (410 kg)
8065-6002	72" (1.8 m)	Ditching	975 lbs. (440 kg)
8045-6020	24" (610 mm)	Excavating	560 lbs. (255 kg)
8045-6021	30" (762 mm)	Excavating	665 lbs. (300 kg)
8045-6022	36" (914 mm)	Excavating	750 lbs. (340 kg)
8045-6023	42" (1.1 m)	Excavating	840 lbs. (380 kg)
8045-6024	48" (1.2 m)	Excavating	960 lbs. (435 kg)
8065-6013	72" (1.8 m)	Dredging	1100 lbs. (500 kg)
8065-6102	40" (1.0 m)	Pavement	1285 lbs. (580 kg)
8065-6024	8' (2.4 m)	Blade	630 lbs. (285 kg)
8065-6009	Single Tooth Ripper		620 lbs. (280 kg)

NOTE: Bucket adjustment values are 87% of the actual bucket weights.

The load point is located on the bucket pivot point, including loads listed for maximum radius.

Do not attempt to lift or hold any load greater than these rated values at specified load radii and heights. The weight of slings and any auxiliary devices must be deducted from the rated load to determine the net load that may be lifted.

ATTENTION: All rated loads are based on the machine being stationary and level on a firm supporting surface. For safe working loads, the user must make allowance for his particular job conditions such as soft or uneven ground, out of level conditions, side loads, hazardous conditions, experience of personnel, etc. The operator and other personnel must fully acquaint themselves with the operator's manual furnished by the manufacturer before operating this machine. Rules for safe operation of equipment must be adhered to at all times.

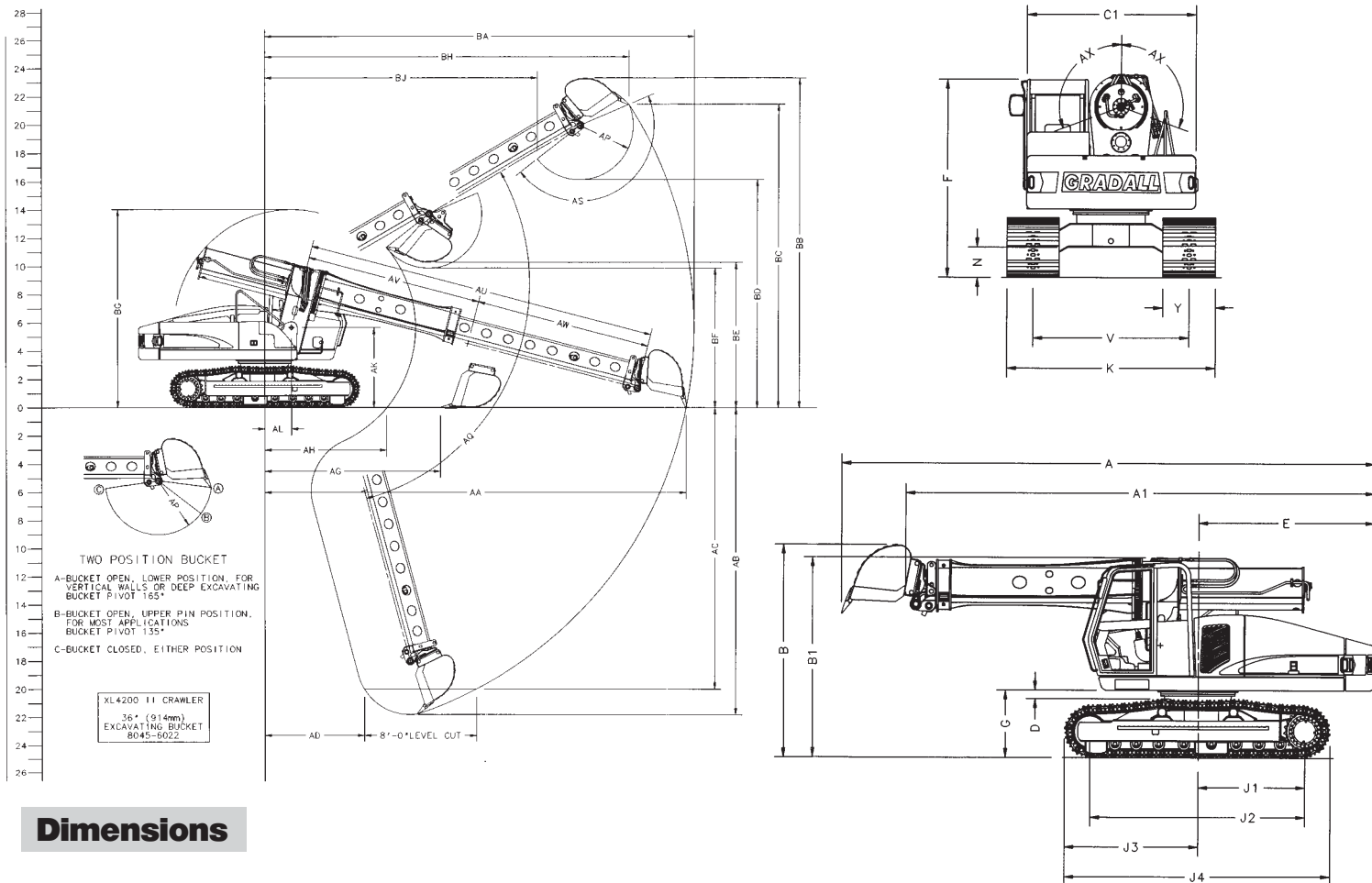

Dimensions

Shown with 8045-6022 36" (914mm) excavating bucket

- A** Overall length with bucket: 27'3" (8.3)
 - A1** Overall length without bucket: 24'0" (7.3)
 - B** Overall height with bucket: 10'9" (3.3)
 - B1** Overall height without bucket: 10'1" (3.1)
 - C1** Width of upperstructure: 8'6" (2.6)
 - D** Minimum clearance, upperstructure to undercarriage: 5" (127 mm)
 - E** Swing clearance, rear of upperstructure: 9'0" (2.7)
 - F** Top of cab to groundline: 9'11" (3.0)
 - G** Clearance, upperstructure to groundline: 3'5" (1.0)
 - J1** Axis of rotation to centerline of drive sprockets: 5'6" (1.7)
 - J2** Nominal distance between centerlines of drive sprockets and idlers: 11'0" (3.3)
 - J3** Axis of rotation to end of track assembly: 6'10" (2.1)
 - J4** Nominal overall length of track assembly: 13'8" (4.2)
 - K** Width of crawler (Standard): 10'6" (3.2)
Width of crawler (Optional): 9'10" (3)
 - N** Ground clearance (per SAE J1234): 18" (457 mm)
 - V** Track gage, roller centerline to roller centerline: 7'10" (2.4)
 - Y** Width of crawler track assembly (Standard): 31.5" (800 mm)
Width of crawler track assembly (Optional): 23.6" (600 mm)
 - AA** Maximum radius at groundline (165° pivot): 30'2" (9.2)
 - AB** Maximum digging depth (165° pivot): 21'9" (6.6)
 - AC** Maximum depth for 8' level cut: 19'11" (6.1)
 - AD** Minimum radius for 8' level cut at depth "AC": 7'2" (2.2)
 - AG** Minimum level cut radius with bucket flat on groundline: 12'7" (3.8)
 - AH** Minimum radius at groundline: 8'9" (2.6)
 - AK** Boom pivot to groundline: 5'8" (1.7)
 - AL** Boom pivot to axis of rotation: 23" (584 mm)
 - AP** Bucket tooth radius: 46" (1168 mm)
 - AQ** Boom pivot angle: 30° Up and 75° Down
 - AS** Bucket pivot angle: 135° & 165°
 - AU** Maximum telescoping boom length (boom pivot to bucket pivot): 25'0" (7.6)
 - AV** Minimum telescoping boom length (boom pivot to bucket pivot): 12'6" (3.8)
 - AW** Telescoping boom travel: 12'6" (3.8)
 - AX** Bucket tilt angle (both sides of center): 110°
 - BA** Maximum radius of working equipment (165° pivot): 30'9" (9.4)
 - BB** Maximum height of working equipment: 23'4" (7.1)
 - BC** Maximum bucket tooth height: 21'5" (6.5)
 - BD** Minimum clearance of bucket teeth with bucket pivot at maximum height: 16'2" (4.9)
 - BE** Minimum clearance of fully curled bucket at maximum boom height (165° pivot): 10'3" (3.1)
 - BF** Minimum clearance of bucket teeth at maximum boom height: 9'11" (3.0)
 - BG** Maximum height of working equipment with bucket below groundline: 14'1" (4.3)
 - BH** Radius of bucket teeth at maximum height (165° pivot): 26'1" (7.9)
 - BJ** Minimum radius of bucket teeth at maximum bucket pivot height (165° pivot): 19'6" (5.9)
- Transport dimensions without attachment
 Length: 24' 0" (7.3)
 Height: 10' 1" (3.1)
 Width: 10' 6" (3.2)

Metric units are meters (m) unless noted

Machines shown may have optional equipment

Optional Equipment

Work lights: 2 spotlights on boom cradle, 3 floodlights on cab, 1 floodlight on right front shrouding.

Vandalism protection kit including window covers.

Intake air pre-cleaner.

Exhaust spark arrestor.

Strobe light.

Block heater.

Additional battery.

Air conditioning.

AM/FM radio installation.

Auxiliary Hydraulics - Inside hose trough with additional hosing and piping for hydraulic powered attachments.
[Maximum pressure 4700 psi (32,400 kPa)
Maximum flow 30 GPM (114 L/min)]

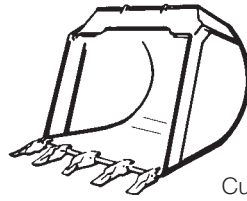

8045-6020	24" (610 mm)	Excavating bucket	Cu. yd.	m3
			3/8	.31
8045-6021	30" (762 mm)	Excavating bucket	1/2	.41
8045-6022	36" (914 mm)	Excavating bucket	5/8	.54
8045-6023	42" (1.07 m)	Excavating bucket	3/4	.64
8045-6024	48" (1.22 m)	Excavating bucket	1	.76

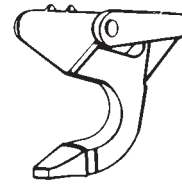

8065-6009 Single-tooth ripper

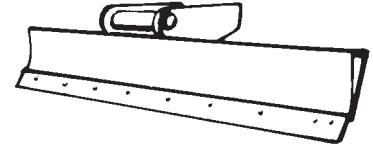

8065-6024 8' (2.4 m) Grading blade

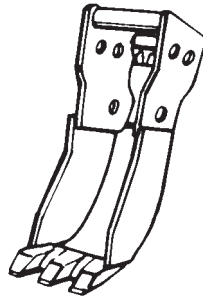

8065-6104	15" (381 mm)	Trenching bucket	Cu. yd.	m3
			1/5	.15
8065-6012	21" (533 mm)	Trenching bucket	1/4	.19

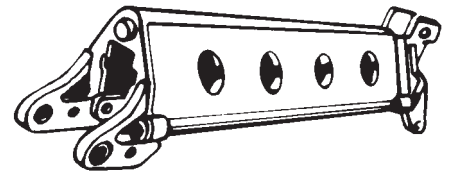

8045-5002 4' (1.2 m) Boom extension
8045-5003 6' (1.8 m) Boom extension
8045-5004 8' (2.4 m) Boom extension
8045-5005 12' (3.7 m) Tubular Boom extension

Attachments

Quick change and reversible buckets fabricated of steel plate, with high strength, low alloy cutting edges and wear strips. Standard attachments available for wide range of applications. Capacities shown are in heaped cu. yd.

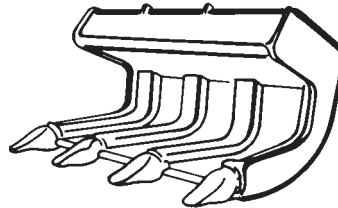

8065-6102 40" (1.02 m) Pavement removal bucket

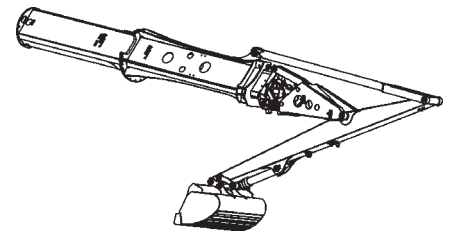

8045-5007 Telestick attachment

It is Gradall Policy to continually improve its products. Therefore, designs, materials and specifications are subject to change without notice and without incurring any liability on units already sold. Units shown may have optional equipment.

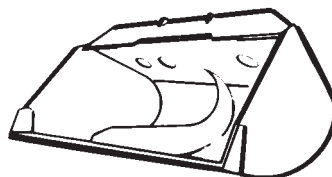

8065-6007	60" (1.52 m)	Ditching bucket	Cu. yd.	m3
			7/8	.73
8065-6006	66" (1.68 m)	Ditching bucket	1	.76
8065-6002	72" (1.83 m)	Ditching bucket	1 1/8	.87

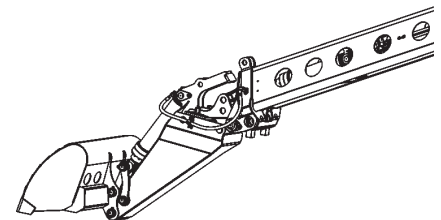

8045-5009 6' (1.8 m) Live Boom

GRADALL®

406 Mill Ave. SW, New Philadelphia, Ohio 44663
Phone: 330-339-2211 Fax: 330-339-8468
www.gradall.com



Certified ISO 9001



8065-6013	72" (1.83 m)	Dredging bucket	Cu. yd.	m3
			1 1/8	.87

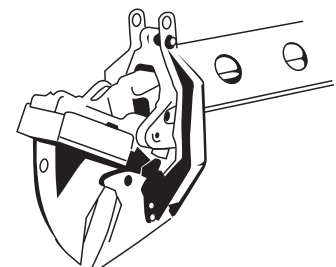

8045-5008 Tree Limb Shear Attachment